

# N GE U25B DIESEL LOCO MOTOR BRUSH REPLACEMENT (A) JAPAN

**FIG. 2**

## *Motor Brush Replacement*

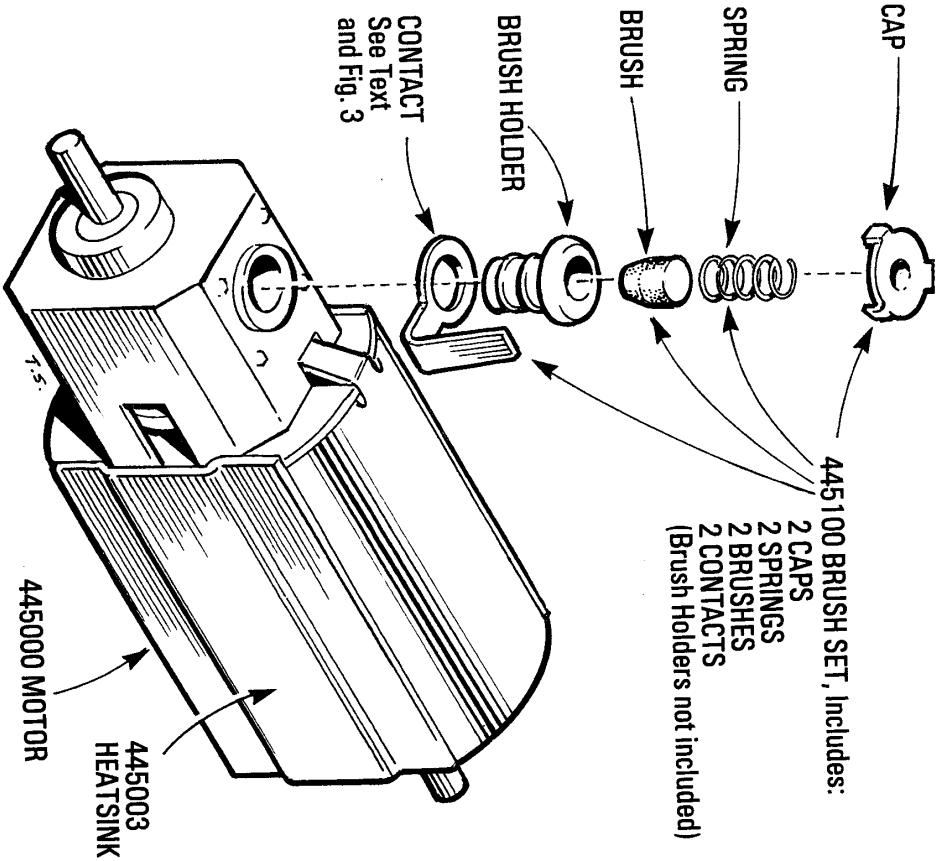

## *MOTOR BRUSH Replacement*

- 1) Disassemble chassis as described on opposite page.
- 2) Lift out motor using extreme care to avoid loss of other drive train components.
- 3) Straighten leg of contact then pull off brush cap. See Fig. 3. Brush spring and brush can now be shaken out of the motor. Replacement brush and spring can be dropped into hole in brush holder and secured by replacing the cap. If contact spring requires replacement use a modeler's knife or jeweler's screwdriver to withdraw the brush holder. Reassemble the brush assembly as shown in Fig. 1.

### **VERY IMPORTANT!**

Contact Springs on Brush Holders *must* face as shown in Fig. 2. If contacts are reversed from position shown, track polarity to motor will be reversed causing loco to run in the wrong direction.

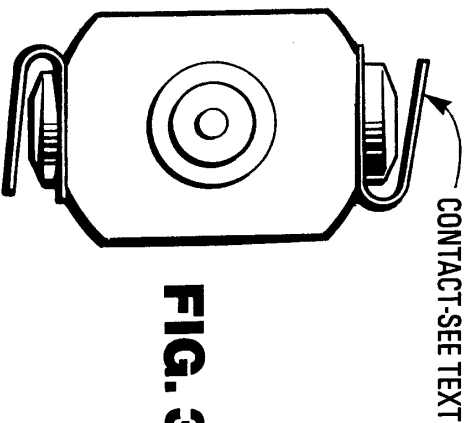

**FIG. 3**

## *Brush Contact Arrangement*

