

ATLAS MODEL RAILROAD CO., INC.

HO EMD GP-7 DIESEL

Mr. Roundhouse Superintendent:

The Atlas HO EMD Diesel has been carefully assembled and tested before leaving the factory. It will provide virtually maintenance free service; however, extended usage may require occasional replacement of the lamp and motor brushes. Major disassembly should rarely be necessary and is not recommended for the novice. Only a person experienced in model loco repair should attempt dismantling the model as shown in the exploded perspective drawing.

IMPORTANT

Before attempting disassembly, all instructions should be read and drawings studied thoroughly so as to become familiar with the locomotive.

BODY & CAB Removal

1) Detach handrails from cab and battery boxes.
2) Place thumb and forefinger on sides of short hood as low as possible. Squeeze gently to release latches. Pull up on short hood and rock forward on long hood to release the latch in the end of the long hood.

3) Cab is secured to body by latches at the bottom of cab front and rear end walls. To gain access to these latches, the short hood light bar/headlight lens, 820204, must first be removed. The latches can now be released from the underside of the body. NOTE: Removal of 820203 cab glazing unit can be difficult and requires care. The glazing unit is molded with eight panes precisely fitted to the individual cab window openings. All eight panes must be released simultaneously before glazing unit can be withdrawn from cab. The following method makes this job easier:

Working one window at a time, push a window out of its cab opening then slip a narrow piece of thin card stock between the glazing and the cab's inner wall to keep it from snapping back into the opening. Repeat this procedure at all other cab windows. With all panes thus held in disengagement, the glazing unit can easily be withdrawn.

TRUCK Removal

Detach truck wires, 820313, by sliding their tiny connectors from the ends of contact wires, 707104. Remove trucks as follows:

1) Remove worm cover, 820304, by gently releasing its four small latches. This will expose various worm shaft components which are best lifted out to avoid their loss while handling the truck.
2) The truck can now be removed by gently pulling down.

The gearcase, with gears, 820302, has been factory assembled and should not be disassembled further.

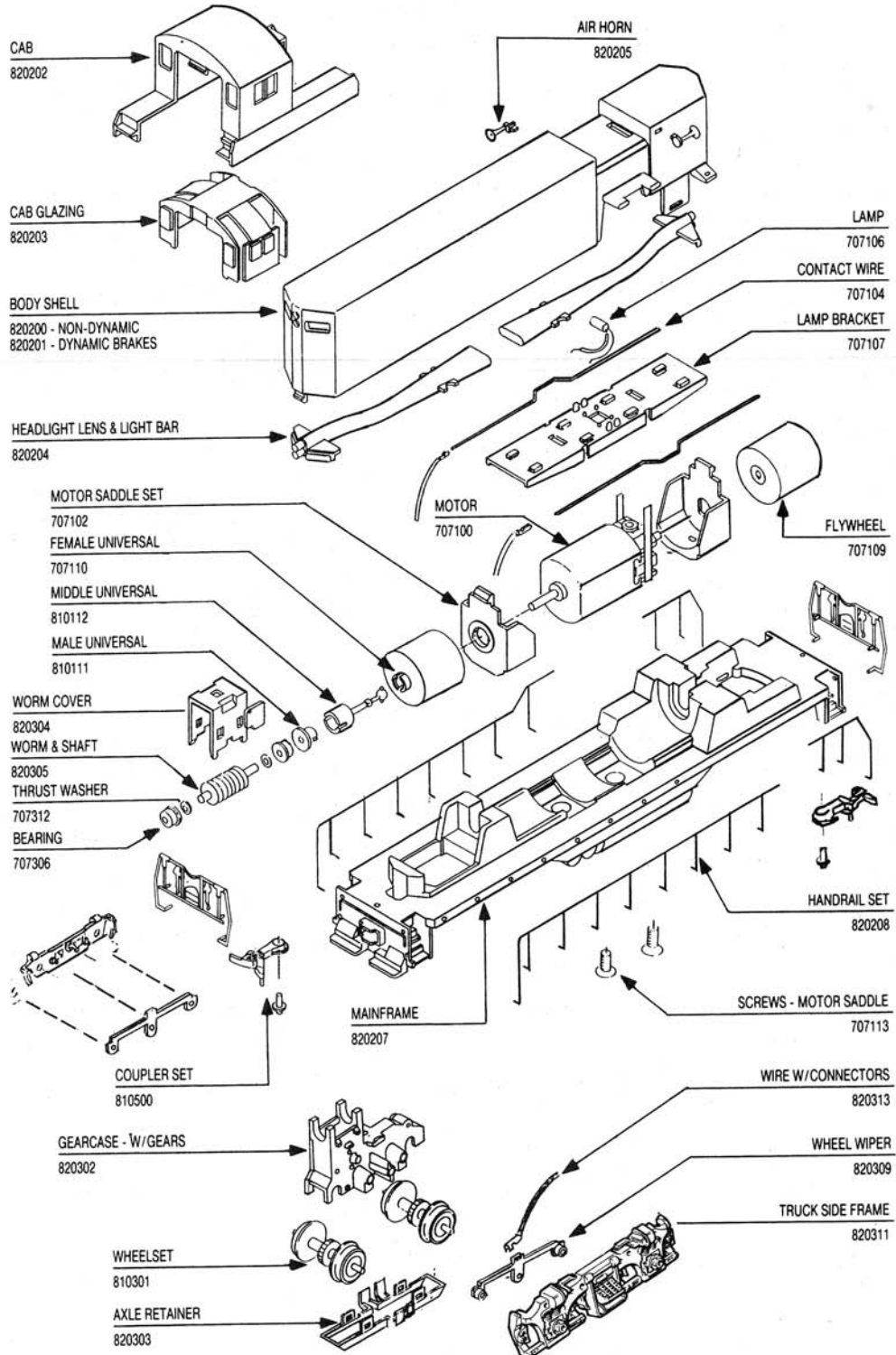

FIG. 1
EXPLODED
LOCO
ASSEMBLY