

UNIVERSAL SWITCH CONTROL BOARD

NON-DERAIL WIRING INSTRUCTIONS

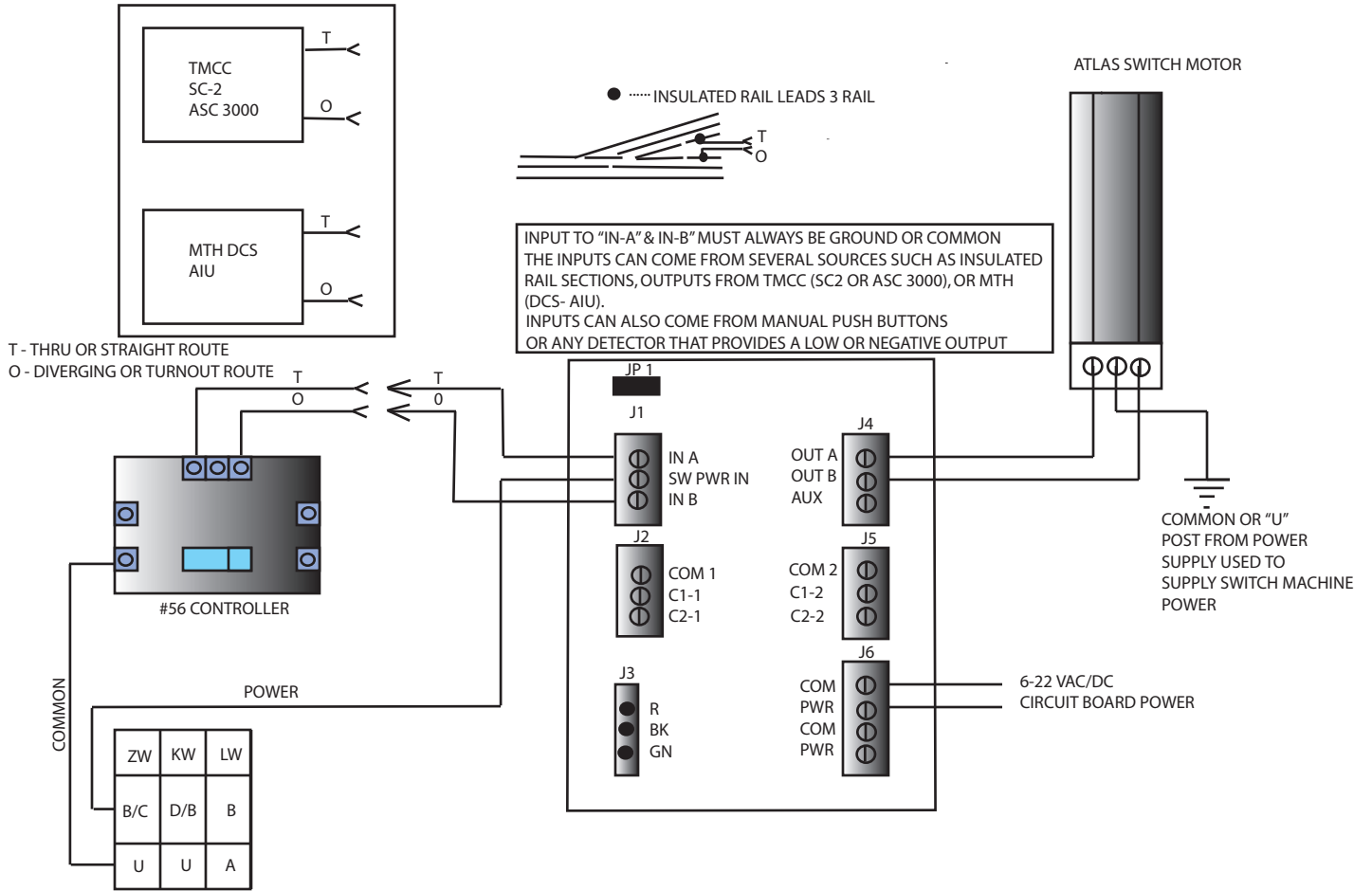

WIRING REQUIRED TO OPERATE ATLAS SWITCH MOTORS UTILIZING THE MANUAL #56 OR OTHER SIMILAR PUSH BUTTON ACTIVATION DEVICE. * NOTE THE WIRING CHANGE FROM THE STANDARD INSTALLATION PROVIDED WITH THE DOCUMENTATION ENCLOSED WITH EVERY ATLAS SWITCH. WHEN USING THE UNIVERSAL SWITCH CONTROL CIRCUIT YOU MUST REWIRE ANY EXISTING INSTALLATION TO MATCH THIS SCHEMATIC .

NOTE ALSO THE CONNECTION FOR SWITCH MACHINE POWER REQUIRED TO OPERATE YOUR SWITCH MOTORS NO LONGER IS CONNECTED TO THE #56 CONTROLLER. YOU MUST CONNECT SWITCH MACHINE POWER TO THE CIRCUIT BOARD J1 TERMINAL MARKED "SW PWR IN". IN ADDITION THE WIRING FROM THE #56 CONTROLLER THAT NORMALLY CONNECTED TO THE TWO OUTER MOST SCREW TERMINALS OF THE SWITCH MOTOR ARE NOW CONNECTED DIRECTLY TO THE CIRCUIT BOARD J1 TERMINALS " IN A " & " IN B " .

THE CONNECTIONS TO THE SWITCH MOTOR ARE NOW CONNECTED TO THE CIRCUIT BOARD J4 TERMINALS " OUT A " & " OUT B " .