

POWERING SWITCH FROGS & AUTO TURNOUT CONTROL WITH USC

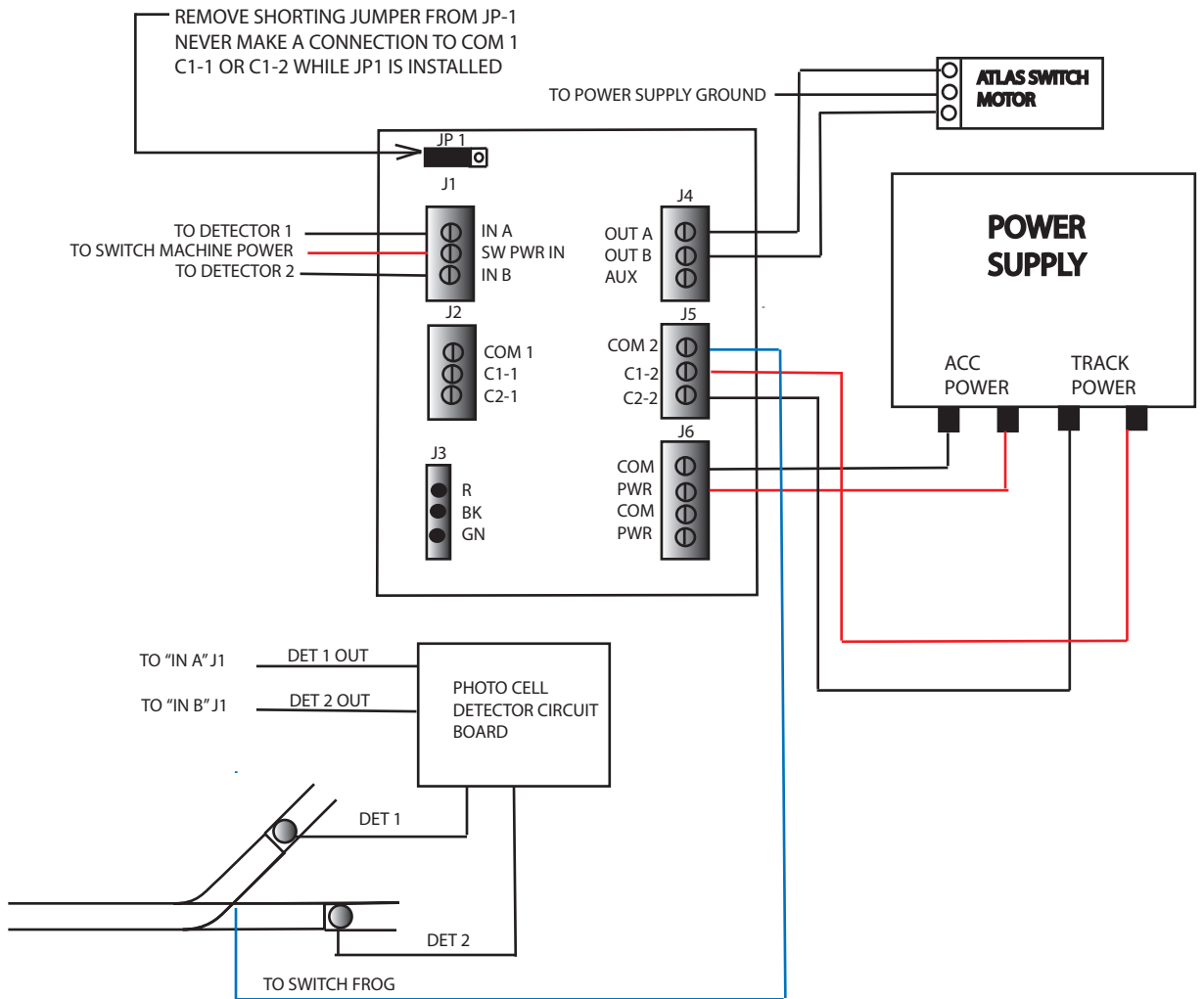

DETECTION FOR TWO RAIL APPLICATIONS WILL BE REQUIRED. THE ABOVE DIAGRAM SHOWS THE PLACEMENT FOR TWO PHOTO CELL DETECTORS. THE OUTPUT FROM THE DETECTORS WILL BE USED TO ACTIVATE THE USC BOARD. THE DETECTOR OUTPUTS WILL CONNECT TO THE USC CIRCUIT BOARD "IN A" AND "IN B". CHECK POLARITY TO FROG TO BE SURE IT MATCHES THE LAYOUT WIRING. IF NEEDED THE POLARITY CAN BE REVERSED BY SWITCHING THE CONNECTIONS TO J5 C1-2 & C2-2. ALSO THE SWITCH MOTOR TURNOUT CONTROL CAN BE REVERSED TO MATCH THE LAYOUT WIRING BY REVERSING THE INPUT "IN A" & "IN B", OR THE OUTPUT "OUT A" & "OUT B".